

Quick Installation Guide

Mobile Wi-Fi

© 2025 MERCUSYS 7100000139 REV1.0.0 *Images are for demonstration only.

Safety Information



- Keep the device away from water, fire, humidity or hot environments.
- Do not attempt to disassemble, repair, or modify the device. If you need service, please contact us.
- Do not use the device where wireless devices are not allowed.

CAUTION!

- Avoid replacement of a battery with an incorrect type that can defeat a safeguard.
- Avoid disposal of a battery into fire or a hot oven, or mechanically crushing or cutting of a battery, that can result in an explosion.
- Do not leave a battery in an extremely high temperature surrounding environment that can result in an explosion or the leakage of flammable liquid or gas. Do not leave a battery subjected to extremely low air pressure that may result in an explosion or the leakage of flammable liquid or gas.

MERCUSYS hereby declares that the device is in compliance with the essential requirements and other relevant provisions of directives 2014/53/EU, 2011/65/EU, 2009/125/EC and (EU)2015/863.

The original EU Declaration of Conformity may be found at <https://www.mercusys.com/en/ce>.

MERCUSYS hereby declares that the device is in compliance with the essential requirements and other relevant provisions of the Radio Equipment Regulations 2017.

The original UK Declaration of Conformity may be found at <https://www.mercusys.com/support/ukca/>

Product Overview

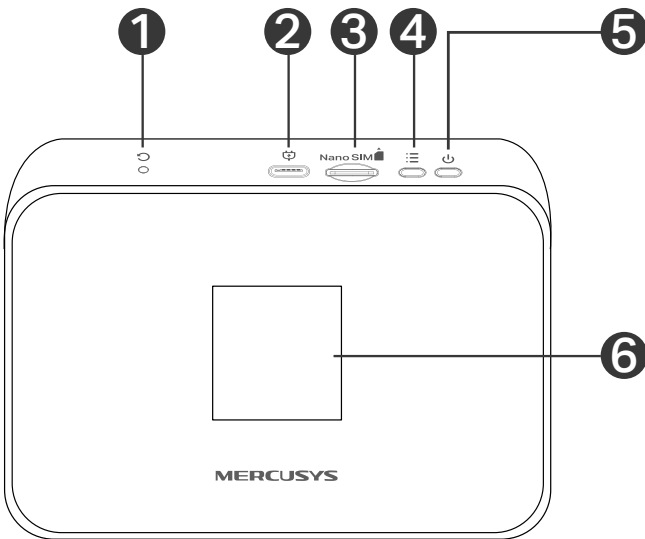

- 1 Reset Button** — Press and hold for 5 seconds to reset the device
- 2 USB-C Port**
- 3 Nano SIM Card Slot**
- 4 Menu Button**
- 5 Power Button**— Press and hold for 3 seconds to power on/off the device, or press to confirm a menu option on the display
- 6 Display**

1. Insert the Nano SIM Card

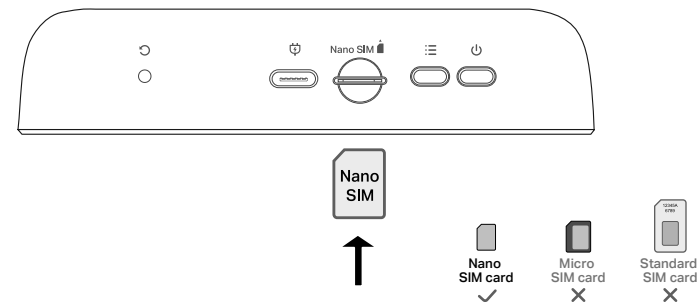

2. Power on your Mobile Wi-Fi

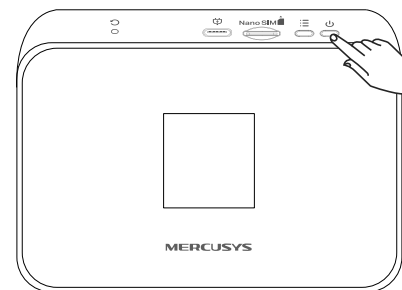

Press and hold for 3 seconds.

- 1** By default, Power Saving is enabled and the Mobile Wi-Fi will turn off Wi-Fi when no wireless devices are connected to it for 10 minutes. To resume the Wi-Fi connection, press the **Power** or **Menu** button.

3. Connect to the Internet

Connect your wireless device to the Mobile Wi-Fi using the default SSID and Wireless Password on the product label. Or, you can press the **Menu** button to switch to the **Device Info** icon, then press the **Power** button to enter the screen and view the SSID and password.

❗ If you cannot access the internet, refer to **FAQ > Q1**.

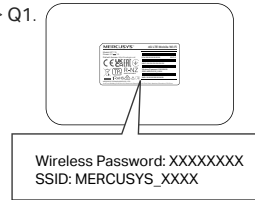
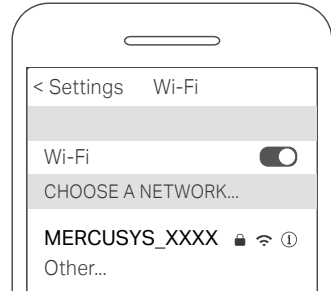

OR

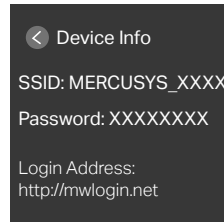

😊 Enjoy the internet!

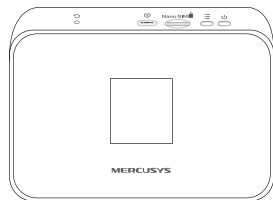

Managing Your Mobile Wi-Fi

Manage your Mobile Wi-Fi using any of the methods below. You can customize Wi-Fi settings, block Wi-Fi devices and more.

Via MERCUSYS App

1. Get the MERCUSYS app from App Store or Google Play, or by scanning the QR code.

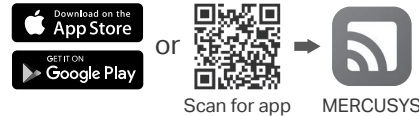

2. Launch the app and log in with your MERCUSYS ID. If you don't have an account, create one first.
3. Follow app instructions to set up the Mobile Wi-Fi.

Via Web Management Page

1. Connect your wireless device to the Mobile Wi-Fi. If it is a computer, make sure it is set to obtain an IP address automatically.
2. Launch a web browser and visit <http://mwlogin.net> or <http://192.168.1.1>. Create a password to log in.

Charging Your Mobile Wi-Fi

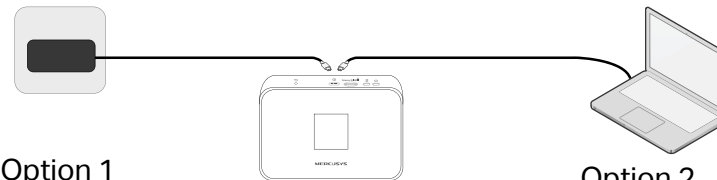

Option 1

Via a Wall Outlet (Recommended)

❗ The power adapter is not provided.

Option 2

Via a Computer

FAQ (Frequently Asked Questions)

Q1. What should I do if I cannot access the internet (one of the following messages appears on the home screen)?

A1. PIN Required

If the current SIM card status is **PIN Locked**, your SIM card is PIN protected. Log into the web management page (<http://mwlogin.net>) and unlock it using the PIN code provided by your mobile carrier.

A2. No SIM Card

Power off your device and reinstall the SIM card.

A3. No Service

- Verify that your SIM card is an LTE or WCDMA SIM card.
- Verify that your SIM card is in your carrier's service area and has sufficient credit.
- Log in to the web management page (<http://mwlogin.net>) on your phone. Go to **Advanced > Dial-up > Dial-up Settings**, then verify that the parameters (i.e. APN, username and password) provided by your mobile carrier are correct. If they are incorrect, enter the correct information or create a new profile, then save the settings.

A4. icon

Enter the Menu screen, go to **Data Roaming**, and turn on **Data Roaming**.

Q2. How do I restore the Mobile Wi-Fi to its factory default settings?

With the Mobile Wi-Fi powered on, use a pin to press and hold the **Reset** button until "**Power Off**" appears on the screen.

❗ Restoring the device to its factory defaults will clear all your settings.



For technical support, user manuals and more information, please visit <https://www.mercusys.com/support>.